

pot talk

2022 Annual Yearbook for the New England Region, SCCA



FROM THE REGIONAL EXEC



While entries were slightly down in 2022, it was a successful year for the club. Membership remains strong and we are now the third largest region in the SCCA. We are thankful to all of our volunteers that work tirelessly behind the scenes to make all of our programs successful.

Every year after our Annual meeting, I am reminded of the rich history of our club. The New England Region SCCA, Inc. has been in existence since 1952 as a result of combining the Boston and other New England Regions which were the founders of the SCCA in 1944. For the past 70 years our members have enjoyed an active program of motorsport competition including rally, solo, road racing, and rally-cross.

As we evolve with the times and technology, a digital and print media and a website have been developed for the publication of events and results and other communication with the members. While we as members will come and go, the Club will continue to be a stronghold of amateur motorsports in the New England Region.

Our members who competed at the National level had great success. **Mark Daddio** was recognized as the Solo Driver of the Year after winning his 13th title with a victory in D Street at the 2022 Solo National Championship. **Steve Introne** won his class (B-Spec) at the 2022 Runoffs, as well as being awarded the Kimberly Cup which is given to the driver showing the most improvement in the past year. In addition,

NER's RallyCross program was recognized at the SCCA National Convention for a Region Achievement award.

I would like to welcome new volunteers in our Solo and Rally programs. **Will Koscielny** and **Melanie Kwong** have stepped up to become Solo assistant co-chairs, and **Chris Martin** and **Tish Munson** have volunteered to become our new rally co-chairs.

At the annual meeting we seated our new board of directors as a result of the elections held at the end of 2022. Board meetings are held on the second Wednesday of every month at 7pm, and are now remote using Zoom. The links to the meetings are published on PitTalk.org and I welcome members to attend. It is your club, help us by giving us your thoughts and input.

I will leave you with one last thought on the subject of volunteering. Our club and all of our programs are made possible by a wonderful group of unpaid volunteers. Please consider volunteering in your program, even if it is for a few hours. Also walk up to one of our volunteers to thank them for all that they do to make it possible for us to compete in this sport that we all love.

Abhi Ghatak



Federal Hill Trading Company
Fedhillusa.com

20% discount for online orders
use code SCCANER during checkout

REGION DIRECTORY

2023 NER BOARD OF DIRECTORS

Regional Exec - Abhi Ghatak - regionalexec@ner.org
Asst RE - Steve Introne - sintrone@yahoo.com
Treasurer - Dick Patullo - patullo@verizon.net
Secretary - George Farrar - gigfarrar@gmail.com
Director - Jeff Adams - Jeffnefv@outlook.com
Director - Jennifer Ferreira - jennferr00@gmail.com
Director - Mark Gregory - rosmarllc@yahoo.com
Director - Hiroshi Hatano - hatanhi@yahoo.com
Director - Paul Omichinski - pomichinski@icloud.com
Director - Dave Patten - futofab@gsinet.net
Director - Dan Sheppard - sheppard_dan@comcast.net

SPECIALTY & PROGRAM CHAIRS

Club Racing - JB Swan - jbswan@ner.org
Autocross - Bob Davis - rr_davis@comcast.net
RallyCross - Chris Martin and Tish Munson - 987687@gmail.com, munsontish@gmail.com
Road Rally - Jon Lamkins - jon.lamkins@cox.net
Social Media - Trevor Hermance - magicaltrevor2@gmail.com
Volunteers - Kelly Messier - nerflagchief@gmail.com
Time Trials - Paul Omichinski - pomichinski@icloud.com
CRE - Peter Morrison - morrisonpeter47@gmail.com

PHOTOGRAPHY CREDITS

Many of the images in this issue of Pit Talk are courtesy of the volunteers and professional photographers that donate their work for our use and enjoyment. We want to thank all of these amazing photographers and ask that the region continue to support their services when looking for photo images.

The Cover Photo is courtesy of **Paxton Blanchard**, highlighting two of our flaggers at Turn 3 at NHMS during the RAL race weekend in August.

Please also thank **Jacob Ronald, Billy Ng, Jon Krolewicz, Best Rally Team, Joe LaCourse Media, James and Rochelle Ray, and Rupert Berrington** for their contributions.



Pit Talk Editor:
Melissa Introne
Introne Communications
Editor@PitTalk.org

INTRONE 
communications
intronecom.com

Pit Talk is the official publication of New England Region, SCCA Inc. It is published online and available free of charge to all members of the Region at PitTalk.org. Articles and advertising do not necessarily reflect the official opinion of either the New England Region, SCCA Inc., the National Organization of Sports Car Club of America, Inc. or the editors of Pit Talk. Articles appearing on the website and in this magazine may be reprinted without written consent provided credit is given to the author, the publication, and the New England Region, SCCA Inc.



TABLE OF CONTENTS

Letter from the Regional Executive	02
Region Awards	04
Division & National Awards	05
Member Anniversaries	06
RAL	07
New Workers	08
Formula E in NYC	09
Teens Welcome	10
NERRC Road Racing Champions	12
NER Proving Ground	14
Runoffs Two-Ways	16
Solo Season Highs	18
80's ReMix	20
Breaking Ceilings	22
2022 Brings Total to 6	24
New RallyX Site	25
RallyX and Road Rally Champs	26
2023 Schedules	28

REGION AWARDS

Every year at the NER Annual Meeting we take a moment to honor those individuals that go above and beyond. The ones that are something special. That work tirelessly, usually behind the scenes, to make sure our programs and events run smoothly and efficiently. These awards are our way of bringing light to the work they do, and offering our thanks and appreciation for the positive impact they make on our club and specifically our region.



Bob Davis

RE Award

Bob has devoted countless hours volunteering his time to our club while balancing his very busy professional career. Two years ago, we needed a volunteer to step in to lead our Solo program, which Bob did. He has continued working to make our already successful program even better, including improving our processes and mentoring our next generation of volunteers who will take over next year.

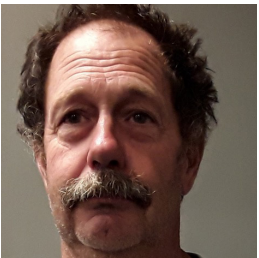

Doug White

Assistant RE Award

Given to a member selected by the Assistant RE who contributes unseen support of the region. This year's recipient embodies that perfectly. If you've come to any club racing event you have definitely seen this person around, usually trying to be everywhere all at once. CRB Chairman JB Swan says "I can count on him to get the small stuff done for road racing without asking. From putting out lunch and dinner, to packing up the trailer. He gets it done. A true unsung hero.



James Ray

Gold Pass Recipient

James has been instrumental in the success for our Club Racing Experience Program which exposes new drivers to road racing. James also is a talented photographer who takes hundreds of photos at every event and shares them with the membership. He has been a mentor and instructor to many of our new drivers.



Roland Clark

Gold Pass Recipient

Roly as we affectionately call him, has been Chief of Tech in our road race program for many years and will be retiring from the position. He has worked tirelessly at all of our road race events and we appreciate his years of service to the club.



Laura "Blossom" and Peter "Thumper" Villaume

MA & PA Philbrick Award

This couple has travelled the country for more than 25 years volunteering in their chosen specialties of Grid and Emergency Services. Laura "Blossom" and Peter "Thumper" dedicate an extraordinary amount of time, and epitomize this honor as workers that enhance our community and develop a family-like atmosphere.



New Hampshire Int'l Speedway.

1989. Timing & Scoring.

No media center. No computers.

Just dedicated workers, outside, in the rain, on bleachers, with stopwatches, clipboards and a typewriter.

In some ways, we can look back fondly on the old days. In this case, technology sure has made this job a lot easier and more convenient.

SCCA

Sports Car Club of America®

New England Region claimed accolades across Road Racing, Solo and RallyCross at both the National and Division levels in 2022. It's a testament to the quality of our events, our leadership, and the dedication of every NER member that participates and volunteers in putting on some of the best racing in the country, and developing the highest caliber of drivers as a result.

Solo Driver of the Year

Mark Daddio

Demonstrated exceptional skills and overcame major obstacles to produce an outstanding performance.

Kimberly Cup Winner

NEDIV Driver of the Year

Steve Introne

A notable and remarkable performance for the year.

NEDIV Rookie of the Year

Jason Conzo

The driver showing the most improvement in the last year.

NEDIV Worker of the Year

JB Swan

The worker who showed the most passion and involvement.

Regional RallyCross Program

New England Region

Largest programs, across multiple sites, with numerous National Championship drivers.

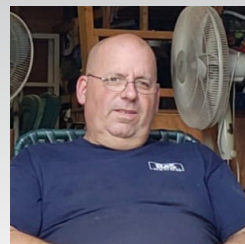
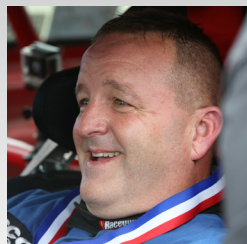

2022 ANNIVERSARIES

New England Region is honored to celebrate these anniversary milestones for SCCA membership. The longevity and dedication to the club through these years of commitment is part of what makes SCCA special. Congratulations members!



50

Joanna Ellis
Philip Gott
Robert Mann
George Miller
Philip Perron
David Pettigrew
Donna Stevens
John Tartaglia

25

Irene Brockway
Chuck Fernandez
Mark Gregory
Marilyn Gudsruk

Melissa Introne
Michael J Lavigne
Tom Less
Elizabeth H Lyons

Maureen Masters
Dennis McCarthy
Christopher G Milton-Hall
Sandra L. Milton-Hall

Russell A Quintal
Bruce Smith
Susan Taylor
Deborah Turner

10

Andrew Bairley
Andrew Barrette
Deborah Branscombe
Jesse Carr
Jessica Carroll
Emmanuel Cecchet
Justin Chen
Joseph A Chimbolo
Daniel Cianci
Jamie Cook
Jojo Corrales-Kean

Jay R Creel
Richard E Currey
J.P. DeVillars
Susan Dixon
James Duggan
Desiree Faulkner
Joseph Faulkner
Cheryl Godfrey
Keith Goring
Jeffrey Joseph Kemp
Mary Kenney

Thomas Kenney
Tatyana Merkuryev
Becca M Nell
Maria Nemchuk
Dana F Nicgorski II
Zachary Perrella
Joel Edward Porter-De Vriese
David Rodman
John Romano
Rodney Rookey
Robert Rund

Glenn Lewis Schattman
Kurt Schmid
Kurt L Smith
Robert David Stager
Sandy Stevens
Derek White
Katie L White
Bryan Williams
Kati Williams
Kaylee Williams
Khloee Williams

5

Payam Aghassi
Tyler Anderle
Jeff Andrews
Kimberley Andrews
Miguelangel Aponte-Rios
Ivor Cary Armistead III
Jeffrey Barnes
Stephan Bastrzycki
Russ Beavis
Genevieve Blethen
Erin Brophy
Paolo Calvo
Kevin Clemens
Francis William Conroy
Kim Conroy
Kendall Cotton
Walter Cramerstetter
Greg L D'Abate
Edward John Day
Robert Melancthon Detrick

Mark C Donato
Brandon Robert Dryer
Keegan Eckart
William Falcone
Janine Farrar
Raul Feliciano Jr.
Dan Fillingim
Brad Fiore
Ian Murphy Fisher
Katharine Fodnaess
Leland Frantz
John J Gooding
David Gran
Albert Harper
Julian Hart
Walt Heinig
William Hendrix
James A Hill Sr.
Seth Holbrook
Jordyn A. Hunter

Rhonda Hunter
Michael Scott Israel
Gavin James
Olivia James
Susan James
Manuel Antonio Jusino
David Robert Kerwood
Glenn Kurkjian
Melanie Kwong
Graham LaBossiere
Evan Leblanc
Mark David Lindsay
Susan Litowitz
Stephen Locke
Albert Lukazik
Judith Lukazik
Mira Lukazik
Hugh Douglas MacLean
Matthew McGuire

James Andrew McKenna
Kelly Messier
Paul Messier
Matthew Morin
John B. Morrison
Vincent Nardone
Austin William O'Brien
Tyler O'Connor
David D Oliveira
J Bradford Parker
Patricia M Pellegrino
Michael Pettengill Jr.
John Robert Piscitelli II
Caleb Allen Pocock
Igor Prokopiw
Gordon Richardson
Matthew J Rodman
Tony Rolfe
Ben Rose

Gary S Rose
Scott A Rosen
Christian Sarnecki
Lori Sarnecki
William J Shields
John F Stanwood Jr.
P RH Stark
Donnie Steele
Hugh Stewart
Timothy Thomas
David Roger Timberlake
Stephen Earle Tise Jr.
Peter Tonelli II
Darius Trinka
Jeffrey M Valeo
Jacob Bradley Voelz
Greg Walters
Deborah Williams
Xinnan Yan

UMASS MEMORIAL FOUNDATION



OVER \$17,000 RAISED

Biggest RAL Weekend Ever

2017: \$10,017

2018: \$9,000

2019: \$15,000

2020: \$8,163

2021: \$13,831

2022: \$17,125

The economy may be uncertain, inflation rising, and everything feels like it just costs more... but even with all of that, New England Region continues to be exorbitantly charitable and generous.

Our 2022 fundraiser for Racing Against Leukemia, which supports children and families battling childhood cancers, was our biggest year to date.

With donations coming in from all programs, the final tally and check being sent to the UMass Memorial Foundation is for \$17,125.

RAL 2022 took place over the August 6-7 weekend, with Road Racing and Rally each hosting events at NHMS, with the annual auction held Saturday night. This year, **Nick Leverone** auctioned off his locks for the fundraiser. Solo dedicated an event the week prior to RAL.

Thank you to every worker, driver, crew member, friend and family and made this possible.

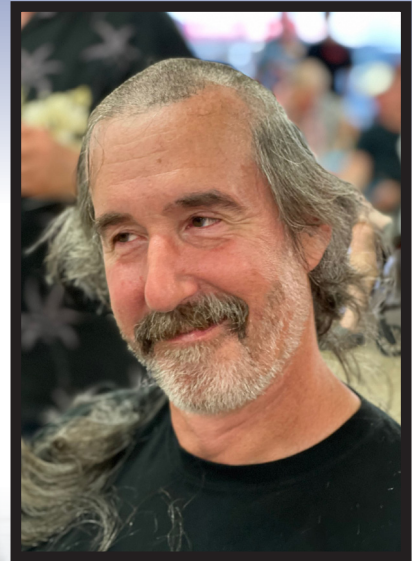

Photo by Paxton Blanchard



NEW WORKERS: JOIN FREE

Just a reminder about our Worker Incentive Program. This applies to both new and existing members. For new workers, volunteer at 3 events and earn a free 1-year membership. NER wants to make it as easy as possible for those interested in helping at events to get out there and become a part of the club.

Weekend 1: Free Trial Membership

Weekend 2: Free Weekend Membership

Weekend 3: Free ONE-YEAR MEMBERSHIP

For existing members, there are incentive programs offered by both NER and SCCA to offset the costs of membership fees, as well as provide rewards that can be redeemed for gas, restaurants, or a variety of stores and retailers. New for 2023, the TRP program will be going digital. Electronic tallies will be kept (no more paper coupons), and the value of each day worked will increase to \$10.

MORE INFO: [NER.org/WorkerIncentive](https://ner.org/WorkerIncentive)



FORMULA E IN NYC

The ABB FIA Formula E World Championship filled the streets of New York City July 16-17, with 22 world-class drivers going wheel-to-wheel in all-electric racing with the Manhattan skyline in the backdrop and the Statue of Liberty watching in the background.

New England Region had a strong contingent of 12 workers present in the Big Apple to support the event. For those thinking flagging a large international professional motorsports events is awesome - well, it is. But not just anyone gets to do it. The best way to get started - come volunteer at your local regional races. This is where the skills are learned and mastered. So when the next big event comes to town, you'll be ready to join in the fun!



NER Workers

- Rich Alexander
- Andrew Benagh
- Scott Butler
- Don Byrd
- Mary Caniero
- Dennis Harrington
- Ben Knight
- Kelly Messier
- Paul Messier
- Brian Pitts
- John Santos
- Justin Wakefield

TEENS WELCOME

Starting at 14, Teens Can Begin Having #FunWithCars



Liam & David Bocchichio
Liam and his dad AutoX in HS

It doesn't take long to find a second, or even third-generation of SCCA racers at an event. With a 70+ year history, SCCA has long been an organization that prides itself on being a family, and that includes making sure our younger members have a way to grow up and continue our love of motorsports.

Bottom line - kids are welcome at our events. We love seeing smiling, young, enthusiastic faces where we can foster a heart for competition, offer a safe outlet to test their limits,

and develop the future racers of tomorrow. "With so many teenagers and young adults getting involved with cars, AutoX is a safe, low cost way to have fun in a car, without putting others at risk or breaking the law," David explains about how why his son Liam has become actively involved.

SCCA and NER make it possible for teens as young as 14 to get on track, start competing, and become a part of the action.

Whether it's chasing cones on a Solo course, getting a Novice permit for Road Racing or RallyX, volunteering in Timing and Grid, setting lap times at Track Nights or Time Trials, or waving flags on corners - there's a lot of ways for our younger generation to get involved.

THE DETAILS

- Minors under 18 are welcome to spectate at any SCCA event. So bring the kids and let them watch!
- Get an Annual Waiver completed. Easy to do online, and streamlines entrance to almost all SCCA events for minors.
- Coordinate a "ride along" - sitting in the passenger seat while another driver competes. This can be during touring laps, pace laps, or even during a hot run, depending on the event and location.
- Volunteer to work. Extra hands are always needed.
- Want to be the competitor? Starting as young as 14, there are pathways to get teen drivers racing licenses and behind the wheel.
- Questions? Contact the Event Chief. Rules and regulations can vary by state, track, facility and specific event. The Chief Steward or Event Chief can answer any questions before you arrive.

PitTalk.org/Minors-under-18



Under 18?



	SPECTATE+	RIDE ALONG	COMPETE/ PARTICIPATE	MINIMUM AGE TO PARTICIPATE	LICENSE NEEDED
Road Racing Volunteer	✓		✓	14	SPECIALITY LICENSE
Road Racing	✓		✓	14	NOVICE PERMIT OR SCCA COMPETITION LICENSE
Solo	✓	✓	✓	15*	STATE ISSUED DL OR PERMIT
Track Night in America	✓	✓	✓	16*	STATE ISSUED DL PARENT PRESENT
Time Trials	✓		✓	16	STATE ISSUED DL AND SCCA COMPETITION LICENSE
RallyCross	✓	✓	✓	16	STATE ISSUED DL
RoadRally	✓	✓	✓	15*	STATE ISSUED DL OR PERMIT

ANNUAL WAIVER NEEDED ANNUAL WAIVER NEEDED

*Permit and driver license ages vary by state.
*SCCA does not require a minor waiver for events open to spectators. Some tracks may have their own requirements.



FOR ALL YOUR MIATA RACE CAR NEEDS

- RACE PREP-
- MAINTENANCE-
- TRACKSIDE SUPPORT-
- GROUND-UP CAR BUILDS-
- SPEC MIATA RACE CAR RENTALS-
- CUSTOM ENGINEERING SOLUTIONS-

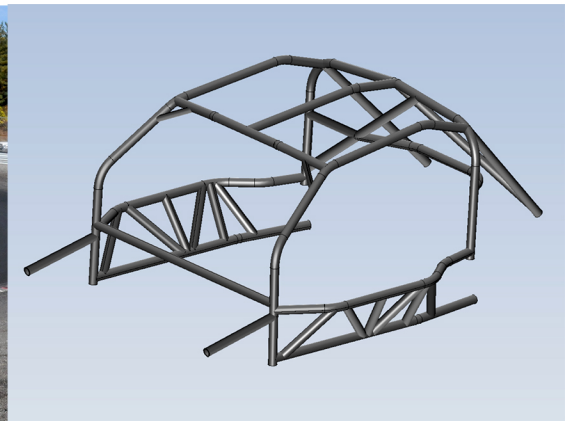

FOR QUOTES & MORE INFO CONTACT

GRANT BARRON

GRANT@MBMPERFORMANCE.COM

(781)201-0141

EVAN McCUTCHEON

EVAN@MBMPERFORMANCE.COM

(603)933-0361



ROAD RACING CHAMPIONS

Congratulations to the 2022 New England Road Racing Champions! After another 8 races this season, 24 drivers claimed their titles. This year brought with it a few unique instances:

#1: **Doug Valley** (GT1), **Todd Parks** (P1), and **Christian Sarnecki** (SM and SM2) each earned Max Points this season!

#2: Christian Sarnecki wasn't a typo... He earned maximum points in 2 of the top 4 attended classes in NER!

#3: We had a TIE in our championship!

In SSM it came down to the Championship Weekend, and with double points on the line **Mark Wheatley** was able to tie it up in the final race of the weekend! That meant it all came down to the tiebreaker: the next best points earned in a single race. Mark had a 3rd place finish, but **Michael Ruggiero** had a 2nd place points finish at the very first race of the year. That NERRC #1 event determined the SSM Championship. Remember - every race matters. So race every race to your fullest.



Photos by James Ray

B-SPEC
Milos Milivojevic

FC
Alex Tollefsen

FE2
Jason Conzo

FP
David Colbey

FV
David Grimes

GT1
Douglas Valley

GT2
Matt Cummings

GTX
Maruizio Cerasoli

IT7
Kenneth Newton

ITA
Jeff Mann

ITR
Jennifer Ferreira

ITS
Kenneth Payson

P1
Todd Parks

SE30
Scott Smith

SM
Christian Sarnecki

SM2
Christian Sarnecki

SPO
Tom Haronian

SRF
Tim Ginalski

SRF3
Lincoln Young

SSM
Michael Ruggiero

STL
Rob Sturgis

T2
Marizio Cerasoli

T3
Allen Briere

T4
Raymond Blethen



NER PROVING GROUND

Another Young Driver Heads to the Pro Series

In 2020, the club racing drivers witnessed the emergency of **Evan Slater**. A 14-yo who transitioned from karting to wheel-to-wheel racing, starting in an SRF3 car prepped by Motion Dynamics.

Fast-forward two short years, and Evan is now a regular on the Trans Am circuit. In 2022, he finished 8th in the overall TA2 Championship points with his highest finish being a 2nd place podium at our own Lime Rock Park track. He'll continue with a full slate of races in Trans Am for the 2023 series.

Now his friend and fellow karting alum, who came with him to SRF3, is blazing his own path to pro racing. It's time to also start watching **Jason Conzo**.

SCCA Highlights

During the 2020 season, Jason finished 2nd in NERRC points for SRF3. He then transitioned over to a Formula Enterprises FE2 car. Moving to open wheel, Jason had to adapt to "a stiffer chassis that requires precise driver input at all levels - braking, turn in, acceleration" he explained. "My level of mental focus had to be higher. The SRF3 was softer and more forgiving. In the FE2, it needs more driver input to get it to respond."

While both cars are challenging to drive in their own separate ways, "the open wheel car felt more like my Go Kart, just bigger. I was able to push it harder and drive it to its limit."

For the 2022 season, Jason set 5 track records in FE2, won the NERRC, won the NE Majors Conference, and in a messy ride through Hurricane Ian at the Runoffs, he secured a 2nd place podium finish at the National Championships. All at the age of 19.

"It has been a great pleasure working with Jason over the past few years," said Shawn Morrison, owner of Motion Dynamics. "Right from the beginning he showed good pace in our cars and has progressed to become a contender for a podium position in any race he participates in. His talent, race craft and enthusiasm is very impressive. He is arguably a great candidate for any racing career as he is young, attentive and passionate about the sport."

Bring on F4

In a just announced deal, Jason signed with Oldfield Motorsports, based out of Atherstone, Warwickshire in England to race F4 this year. Jason will be one of only two Americans racing in the British GB4 series for 2023.

MotorSport Vision launched the GB4 series in 2022 as an entry-level championship for aspiring F1 drivers. He'll be sitting in a Tatuus F4-T014, one of the most successful single-seater cars produced in recent decades. The same racecar that was driven by current F1 stars Lando Norris, Lance Stroll and Mick Schumacher to launch their careers.

"I wanted to challenge myself and gain some international experience competing against my European counterparts. Performing well in the GB4 series will help promote my name at an international level and hopefully advance my racing career. I have to thank my parents for supporting me and helping me get to this level."

2023 Schedule

Jason's F4 season will kick off in March with a Donington Park Test & Media Day. Then he's slated to test and drive at events in April and May.





2023 Conzo GB4 Schedule

March 23
Donington Park Test &
Media Day

April 5-7
Oulton Park Test
April 8-10
Oulton Park Race #1

May 4-5
Silverstone Test
May 6-7
Silverstone Race #2

North Atlantic Racing Academy

(formerly known as The Miata School at Thompson)

Earn Your Learners Permit in 1 Day!

Wednesday, May 24, 2023
Thursday, June 8, 2023
Wednesday, July 5, 2023
Tuesday, August 8, 2023
Tuesday, Sept. 5, 2023
Wednesday, Oct. 11, 2023

NARA is hosting a limited number of one-day race school events for the upcoming season.

Sign up today to reserve your spot.
Each class is limited to 8 students.

Investment: \$1,895.00 includes car rental



Contact Lou Gingerella: 860-460-0930
NorthAtlanticRacingAcademy.com

RUNOFFS TWO-WAYS

Qual in Sunny and Dry, Race in a Hurricane

The 2022 National Championship Runoffs were a tale of two weather systems. For all of practice and qualifying, the Virginia International Raceway was bathed in cool temperatures, clear, and sunny skies. Perfect race weather. Then as Qualifying came to a close, the remnants of Hurricane Ian arrived overnight on Thursday.

In addition to heavy rains, multiple areas surrounding the track lost power and faced fallen trees. The first day of championship races on Friday were in conditions nothing close to the days leading up. The volunteer workers that braved the rain, cold and wind were nothing short of heroic. Unlike drivers that had just one race to battle the elements, the workers spent the entire day in it. In a first, racing was shut down entirely, and the FX race was cancelled for Friday and moved to Saturday morning. This required the entire Saturday schedule to be adjusted and the races shortened to accommodate.

As the worst of it passed through, Saturday conditions were still less than ideal – misting, rain and overcast alternating back and forth. Drivers were forced to do the rain dance – are we running wets or drys? During the Spec Miata race, the commentators were heard remarking that half the track was in downpours while the other half had dry lines!

Sunday brought the more consistent rain back. But as the event closed on Sunday, all 26 races were run and 26 National Champions crowned for the season.

NER Podiums

In his 5th Runoffs appearance, **Steve Introne** was the sole NER National Champion in 2022. After finishing 3rd last year at Indy, Steve came prepared with a week-long strategy that included a partnership with **Rich Hromin**, who finished just 78/1000 behind Steve at the checker.

In addition to the top podium spot. Steve was honored with the SCCA podcast Veterans Challenge Driver of Distinction, the Gee Dubb Henderson Award of Excellence, and was just selected for the national Kimberly Cup, given to the most improved driver of the year, and NEDiv Driver of the Year.

The only other podium appearance went to **Jason Conzo** in his #04 Formula Enterprises 2 car. With a P4 starting position on the grid, Jason had a fabulous start and quickly took the lead, which he held for the first nine laps of the race. But with zero visibility in many parts of the course due to the rain, an off track excursion dropped him back to third. With just two laps to go, Jason found the opening, made that final pass and finished in 2nd place. For his first visit to VIR, it was an impressive performance for the young driver, who just secured a pro ride in F4. (See the “Proving Ground” article on page 14.)

Other notable performances came from **Nick Leverone** and **Thomas West**, each just missing the podiums with 4th place finishes in T4 and AS. Nick was battling hard in his SM race, running 4th for most of the time, until one small error sent him off track and to the back of the pack with only two laps to go. Not enough time to recover, and a hard way to end that race.

NER Block Party

On Wednesday night, the Runoffs hosted its annual Block Party – similar to our NER Paddock Crawl. The turn out at the NER paddock spots in the West Grass was outstanding. **JB Swan, Greg Amy, Anthony Ruddy, Kathy Barnes** and many other NER members served well over 200 people ribs, burgers, hot dogs, chips, and all sorts of other foods. The region was a magnet for everyone else with its kegs and taps from our local breweries that were served up. Big thanks to **Black Hog Brewing, Glasstown Brewing**, and some non-alcoholic options from **Athletic Brewing** for donating the beverages.



Get some Grip!

We're your source for Alpha Racing Tyres, Federal, Fedima, and Zestino Rally, Rallycross, AX, TT, Drift and Stage Rally DOT Tires!



Jason Conzo and family/crew atop the podium for his 2nd Place FE2 finish



Steve Introne heads out for the longest victory lap in Runoffs history. Stopping at every flag station to thank the workers.



ALPHA
RACINGTYRES



FEDERAL[®]

Motorsports

FEDIMA

motorsport

ZESTINO

NERacingTires.com



SOLO SEASON HIGHS

24 Reg'l Champs, 4 Nat'l Champs & New Timing System

The 2022 Solo schedule consisted of 11 events over a nine month period between April and October. After all the runs, all the cones collected, and all the points tallied, 24 Autocross drivers wrapped up their season with a NER Championship trophy.

Solo continues to operate and host events at Devens Airfield in Ayers, MA. With a schedule that starts in early spring, continues through the heat of summer, and wraps up in the fall, these competitors must come prepared to race in all the conditions.

The Solo program wants to thank **Bob Davis** for stepping up and returning to his role as Solo Chair for the last two seasons, and are excited to welcome **Will Koscielny** and **Melanie Kwong** as his assistant chairs in 2023, with the plan for these two to take over the reigns.

Congratulations to **Grant Reeve** on claiming his 3rd Stirling Moss trophy, and to **Steve Twaddle** who was selected for this year's Charlie Award. And the 2022 National Solo Driver of the Year is our own **Mark Daddio**.

NER's AutoX program continues to produce some of the most talented drivers in the country, as witnessed by our performances at Solo Nationals. In 2022, 2 more National Titles were claimed and 2 more ProSolo Champions crowned. We also have a strong presence in building and promoting the Women on Track program.

Looking forward - there will be a redundant timing system for the 2023 season. Last season was plagued with timing issues, so this is welcome news.

There's always lots of action on an autocross course, so come join the fun at one of the 2023 race days.



2022 Champions and Chiefs



Grant Reeve claimed his 3rd Stirling Moss trophy.





Photo by
Genya Seredkin

**Street
Categories**

AS
Russ Siggelkoe

BS
Michael Elkhort

DS
William Koscielny

ES
John Frongillo

FS
Ralph Zajac

GS
David Gott

HS
Josh Brockman

SS
Brendan Wong

STH
Justin Malinsoky

STS
Brandon Dean

STX
Evan LeBlanc

STR
Theresa Doyon

STU
Jacou Ronald

SST
Benson Tai

**Prepared
& Modified
Categories**

SSP
Shaun Moore

XP
Thomas Moore

DP
Donald Allen

AM
Bob Barone

CM
Jim Garry

SM (FWD)
Don Kuehl

SM
Matthew Mickle

CAMC
Jeff Bakken

CAMT
George Farrar

XSA
Justin Chen

XSB
Nathan Winters

PRO
Grant Reeve



Photos by Jacob Ronald



80'S REMIX

Solo Nats Goes Retro, NER Brings Home 4 Titles

Break out the neon, leg warmers, and big hair bands – because the Solo drivers went BACK TO THE 80'S for the 2022 Solo National Championships. Another great week, where the racing was amazing, but the people and friends are what truly what make this event special.

This year, NER sent 32 competitors to Lincoln, Nebraska and showed, once again, why our region is considered one of the best when it comes to producing competitive Solo drivers. 2022 finished with NER claiming 2 National Championship titles as well as 2 ProSolo Series Champions. Four titles is amazing, but it could have been so much more. We had 4 second place finishes (just missing that top step on the podium), and four 3rd places as well.

Keeping with the tradition of team t-shirts, NER members were easily spotted around the course in their bright neon-green PAX MAN shirts and NER temporary tattoos. As always, we can thank **Jojo Corrales-Kean** for making those happen.

Highlights

- **Ginette Jordan** overcame a half a second deficit in her last heat to claim her 14th National Championship title. (15 if you count a provisional class win!)
- **Tamra Hunt Krystinik** became the first woman in 17 years to win an open Pro Solo (and the ONLY woman to win an open ProSolo and a National Championship. She also came within just 0.089 seconds of winning another National Championship in DSP this year. She also finished 10th overall in PAX, the highest placing woman.
- **Mark Daddio** took home is 13th National title, beating second place by almost a half a second.
- **Billy Davis** also joined in the ProSolo titles by claiming his season championship in STR,
- Despite multiple mechanical issues during multiple runs, **Todd Kean** still came in 2nd in SSM in an SM car.

Photo by Jon Krolewicz



Photo by Rupert Berrington



Mark Daddio
2022 D Street National Champion
2022 National Solo Driver of the Year

2022 Solo Nats Results

National Champions

D Street (DS): Mark Daddio

(13th Nat'l Title, 3rd in Class)

F Street Prepared Ladies (FSL):

Ginette Jordan

(14th Nat'l Title, 3rd in Class)

ProSolo Champions

Street Touring Roadster (STR):

Billy Davis

Street 1 (S1):

Tamra Hunt Krystinik

Trophy Finishes

Super Street – 5th Place – Pat Salerno

H Street – 6th Place – Mark Panusky

Super Street R – 2nd Place – Grant Reeve

Street Touring Ultra – 3rd Place – William Koscielny

Street Touring Ultra – 10th Place – Jacob Ronald

Street Touring Roadster – 2nd Place – Billy Davis

Street Touring Sport – 8th Place – Brandon Dryer

B Street Prepared – 5th Place – Brad Fiore

D Street Prepared – 2nd Place – Tamra Hunt Krystinik

Super Street Modified – 2nd Place – Todd Kean

C Modified – 3rd Place – Reid Shanabrook

Honorable Mention

G Street Ladies – 3rd Place – Melanie Kwong

Street Modified Ladies – 3rd Place – Jojo Corrales-Kean

Trophy Finishes

Street 2 – 3rd Place – Grant Reeve

Street 3 – 4th Place – Jacob Ronald

Street 3 – 5th Place – Pat Salerno

BREAKING CEILINGS

Tamra Hunt Krystinik - First Female to Win Open ProSolo in 17 Years, Only with A Nat'l Champ Title Too

SCCA's Women on Track program is working hard to break down barriers and get more females involved in the world of motorsports.

Drivers like **Tamra Hunt Krystinik** are proving that women not only belong on track, in many cases, they can do it better.

At this year's Solo Nationals, Tamra became the first woman in 17 years to win a ProSolo Championship in an Open class. Only two other ProSolo open female champs have occurred, **Lynne Rothney-Kozlak** in FS in 1997 and 2003, and **Kyung Wootton**, who did it in 2005 in CS. For those needing a little clarification, Open classes have both men and women competing against each other on the same level. Ladies classes are for women only.

"Fun fact, I've competed in Ladies four times at the finale, and yesterday was my first finale win, and it was in open! Ladies class competition is tough," Tamra noted. "I'm a big supporter of ladies classes and would not be where I am today without them."

In 2019, Tamra won the DSP National Championship title, again in the open class, making her the sole owner

of a championship title in both. There are only four other female open National Champions ever as well.

Besides her ProSolo win in S1 this year, Tamra went into the Challenge round and finished 10th in the overall indexed results, giving her the highest placing by a woman.



"I'd like to thank the Davis family for taking me under their wing when I first started autocrossing, and the opportunity to drive their CSP car and learn from them," Tamra explained. "Also, my husband, Andrew, for being the best teammate ever."

For 2023, Tamra and Andrew are building a B-Mod car that they'll compete in. So keep an eye on this pair, and particularly this amazing driver, as she continues to leave her mark on SCCA Solo courses.

Photo by Billy Ng



SCCA Women ON TRACK

If this year's results don't speak loud enough – **Ginette Jordan** winning her 14th title and **Tamra Krystinik** being the first woman to win a ProSolo and a National Championship in an open class – NER develops and promotes highly skilled and competitive female autocrossers. Our commitment to getting more women on track, and opening the doors for women to participate in any aspect of motorsports, is near and dear to our hearts.

This year, **Jojo Corrales-Kean** and Tamra both served on the WoT Committee and helped host the Ladies Brunch at Solo Nationals. More than 100 women attended. Their dedication to building connections allows the WoT program to introduce, support and grow female participation and #funwithcars.



NER MERCH

Coming in 2023, NER Merchandise will be available to order online. Watch for a new section on the NER.org website, where orders can be placed directly for fulfillment, instead of needing to mail a paper form.

As always, **Donna Stevens** will be available at all Road Racing events with merchandise on site for purchase.

Questions? Reach out to Donna.

[NER.org/merch](https://ner.org/merch)



TEC TOOL & EQUIPMENT CONNECTION

63 George Leven Dr. North Attleboro, MA 02760
888-594-7800 • www.teclifts.com • glenn@teclifts.com



OFFERING EQUIPMENT SOLUTIONS TO IMPROVE YOUR GARAGE ENVIRONMENT



• SERVICE LIFTS • STORAGE LIFTS

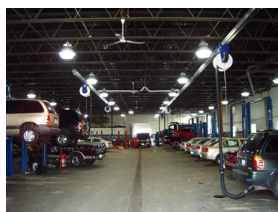

EXHAUST EVACUATION SYSTEMS



AIR AND LUBRICATION SYSTEMS



GARAGE CABINETS AND FLOORS

- Jacks and Stands • Cabinetry • Garage Flooring • Garage Storage • Tool Boxes
- Shop Equipment • Work Benches • Waste Oil Management • Certified Lift Inspectors

2022 BRINGS TOTAL TO 6

Warren Elliot and his BWM Claim a 6th Nat'l Title

Warren Elliot and **Hal Denham** hauled their 2002 Mitsubishi EVO, nicknamed the BWM "Black Winged Monster" to Pikes Peak International Raceway in Fountain, CO in September for the RallyCross National Championship. The long haul proved worth it, as Warren claimed his 6th National Championship title in Prepared All-Wheel Drive (PA).

"We had an uneventful 3-day trip," Warren shared on the drive out to Colorado. "We spent a couple days acclimating to the high altitude." At race time, it was clear that the Evo was the car to have for the Pikes Peak course. "Three of us in PA were in the car of choice, an Evo IX." In fact, Evo drivers finished first, second and fourth in PA. Warren continued, "I was able to set a very fast first run which meant the others were playing catch up both days. I entered day 2 with a 8.999 second lead. I was able to drive conservative on Sunday and was clean for all nine runs."

After the final run Sunday afternoon, Warren kept a commanding 6.3 second lead, giving him the National Championship. He wanted to make sure and thank "Hal, Meadesport, RRT and Hale Motorsport" for all their support.



Photo by Warren Elliott



Photo by Best Rally Team
bestrallyteam@gmail.com

NEW RX SITE: XMAS TREE FARM

New England Region added a new RallyCross site to its venue list in 2022. A huge thanks goes out to **Scott Carlson** and **Phil LaMoreaux** for all of their hard work over the last year to make this happen.

Glove Hollow Christmas Tree Farm in Plymouth, NH is nestled in a few gentle mountains bordered with lakes, and absolutely beautiful. About a year ago, Phil connected Scott with the owner, **Mike Ahern**. Mike's property is on the west bank of the Pemigewasset River just south of the town of Plymouth and is comprised of forested land, a Christmas tree plantation (75,000 Fraser and balsam fir), and an open field for hay.

The first event was the RallyX of Little Pines on November 7. The site offers easy access to the paddock with the grid area close by. The course was rock free for the duration of the event, which mean drivers did not have to dodge rocks and worry about our oil pan! This is an ideal spot, with food, services and access to the highway close by. If you live in the area, next winter stop by and get your Christmas trees here, telling them NER RallyCross is the reason you are there!



Photo by Joe LaCourse Media

RX: BY THE NUMBERS

9 Events, 6 Titles, 4 Committed Drivers

RallyCross runs year round. There is no “off season”. The first points event was January 15, and the final points event didn’t conclude until December 3. After **Joel White** finished the final tally, 6 drivers qualified and earned a 2022 Championship title.

Highlights

2022 set a record number of events, hosting 9 RXs, including adding another new venue. Also, in a show of spectacular commitment, 4 drivers made it to every event of the year! Those dedicated drivers are **Ian Fisher, Michael Maurice, Clifton Kangus, and Kathy Moody.**

Also worth noting regarding Kathy – she competed in SR, PF, MR and MA throughout the season, probably making her one of the most versatile drivers around.



Photo by Joe LaCourse Media

2022 Season Champions

R: George Farrar

PA: Michael Maurice

SF: Austin O’Brien

MF: Stephanie Reeve

SA: Ian Fisher

MA: Clifton Kangas



Ted Goddard Lifetime Achievement Award

Gerald and Julie Goulet

ROAD RALLY TITLES

2022 Season Champions

Class E Driver: Michael Beliveau
Class E Navigator: Chris Regan

Class L Driver: Dan Hayes
Class L Navigator: Ashely Hayes

Class S Driver: Chris Wright
Class S Navigator: Paul Longtine

Cameron Dewars:
Chris Regan

CONNECTICUT AUTOCROSS & RALLY TEAM



DON'T JUST WATCH
**GET OUT
AND DRIVE!**

Do you have a need for speed?

Join CART for their 2023 season!

Time Trial Dates-

Thompson Speedway - May 20th & Sept. 30th
Palmer Motorsports Park - August 26th

Autocross & Road Rally Dates-

To be announced soon!

**Autocross
Time Trials
Road Rallies**



www.cartct.com
www.motorsportsreg.com

Or scan the QR
code with your
smartphone



2023 SCHEDULES

The Solo, Rally, and Club Racing boards have released the following schedules for the 2023 season. Some dates are tentative and may change. Please visit the schedule pages on the NER.org website for the most current information and links to registration, supps, and all event details.

ROAD RACING

[NER.org/2023-NERRC-Schedule](https://ner.org/2023-NERRC-Schedule)

April 20-21
Thompson Drivers School

May 6-7
#1 Granite State Regional + CRE
New Hampshire Motor Speedway

June 16-17
#2 Paddock Crawl
Lime Rock Park

July 8
#3 Midnight Madness
Thompson Speedway

July 29-30
#4 RAL + CRE
New Hampshire Motor Speedway

August 18-19
#5 NER Majors
Thompson Speedway

September 9-10
#6 Pig Roast + CRE
Palmer Motorsports Park

October 13-14
#7 Championship Weekend
Thompson Speedway

Photo by Paxton Blanchard



RALLYCROSS

Photo by Joe LaCourse Media

Jan 14:
Feb 4: 508 Winter Series
Mar 11:

April 29: Blue Lot Spring
May 20: Mt Snow
June 24: Union, ME
Sept 29: Blue Lot Fall
TBD: Little Pines



[NER.org/2023-Rally-Schedule](https://ner.org/2023-Rally-Schedule)

ROAD RALLY

Feb 18: Winter Challenge
April 1: Cape Codders Courageous
April 23: Seacoast Scramble
Aug 5: RAL GTA
Sept 9: Hurdle



AUTOCROSS

NER.org/2023-Solo-Schedule

Photo by Jacob Ronald



POINTS EVENTS

April 23
May 7 & 27
June 11
July 9
August 6 & 20
September 17
October 8

KNOCK OFF THE RUST

Non-Points
April 2

EVO DRIVING SCHOOL

With Boston BMW
June 24-25

STIRLING MOSS RUNOFF

October 8

TEAM CHALLENGE

October 28

DEVENS INTERCLUB CHAMPIONSHIP

October 29

TNIA & TIME TRIALS

NER.org/2023-Time-Trials-Schedule

TrackNightInAmerica.com/Events

2023 TIME TRIALS SCHEDULE

May 20 @ Thompson Speedway
September 30 @ Thompson Speedway
TBD @ Palmer Motorsports Park

2023 TNIA SCHEDULE

Lime Rock Park; Lakeville, CT
April 27, June 7, June 8, July 17, August 17

New Hampshire Motor Speedway; Loudon, NH
May 5, July 28

Palmer Motorsports Park; Palmer, MA
June 22, September 7

Thompson Speedway Motorsports Park;
Thompson, CT
April 18, May 11, May 23, June 29, July 11, July 20,
August 10, August 29, September 21, October 10





2023

SCDA Schedule



Register Online: www.SCDA1.com

* NOVICE Group NOT Available

1/21- Sat	Lime Rock - Winter Car Control Clinic	7/18- Tue*	Lime Rock Park- (UNMUFFLED event) (1pm-5)
2/18- Sat	Lime Rock - Winter Car Control Clinic	7/24- Mon	Thompson Speedway Motorsport Park
3/11- Sat	New Jersey Motorsports Park - LIGHTNING (1pm-5)	7/31- Mon	Club Motorsports
3/12- Sun	New Jersey Motorsports Park - THUNDERBOLT (9am-1pm)	8/7- Mon	Palmer Motorsports Park- Clockwise
3/25- Sat	Lime Rock Park – Car Control Clinic (9am-12)	8/12- Sat	Lime Rock Park – Car Control Clinic (9am-12)
3/25- Sat*	Lime Rock Park (1-5pm)	8/12- Sat*	Lime Rock Park
4/17- Mon	Lime Rock Park	8/20- Sun	Thompson Speedway Motorsport Park
4/17- Mon	Lime Rock Park – Car Control Clinic (10am-1)	8/28- Mon	Watkins Glen International
4/22- Sat	Thompson Speedway Motorsport Park	8/29- Tues	Watkins Glen International
5/1- Mon	Watkins Glen International- Long Course	9/11- Mon	Lime Rock Park
5/2- Tue	Watkins Glen International- NASCAR Short Course	9/11- Mon	Lime Rock Park – Car Control Clinic (10am-1pm)
5/12- Fri	Lime Rock Park	9/15- Fri	Palmer Motorsports Park-Counterclockwise
5/12- Fri	Lime Rock Park – Car Control Clinic (10am-1)	9/23- Sat	Thompson Speedway Motorsport Park
5/18- Thu	Pocono Raceway	10/2- Mon	Virginia International Raceway (VIR)
5/26- Fri	Palmer Motorsports Park- Counterclockwise	10/3- Tue	Virginia International Raceway (VIR)
6/5- Mon	Pittsburgh International Race Complex	10/9- Mon	Lime Rock Park
6/6- Tue	Pittsburgh International Race Complex	10/9- Mon	Lime Rock Park – Car Control Clinic (10am-1)
6/10- Sat	Thompson Speedway Motorsport Park	10/17-Tues	Palmer Motorsports Park-Clockwise
6/15- Thu	Lime Rock Park	10/21- Sat	Lime Rock Park – Car Control Clinic (9am-12)
6/15- Thu	Lime Rock Park – Car Control Clinic (10am-1)	10/21- Sat*	Lime Rock Park (1pm-5pm)
6/26- Mon	Club Motorsports	11/3- Fri	Lime Rock Park – Car Control Clinic (9am-12)
7/10- Mon	Watkins Glen International	11/3- Fri*	Lime Rock Park (1pm-5)
7/11- Tue	Watkins Glen International	11/19- Sun	New Jersey Motorsports Park- LIGHTNING
7/18- Tue	Lime Rock Park – Car Control Clinic (9am-12)		Private Run Groups & Events Available

RETURN ADDRESS:
 PIT TALK
 SCCA, NEW ENGLAND REGION
 18 HIGHCLERE RD
 WINDHAM, NH 03087

SCAN
 for
 SCHEDULES

2023 Rally



2023 NERRC



2023 Solo



2023 TT/TNIA



Gerard
 Callaghan



Burning The Midnight Oil

Jason
 Dube



Most Improved Driver

2022 NEFV Champion - David Grimes
 2nd in Points - Chris Barry
 3rd in Points - Tom Kenney



Zavos
 Bros.



Rookie of the Year



Thank You 2022 Sponsors

Autowerks Racing Engines

Quixote Racing

Hoosier Tire East

Penske Racing Shocks

Pestell Design



NEFV.org
 Northeast Formula Vee. Org